

# Liquid Storage Management for the Water and Wastewater Industries

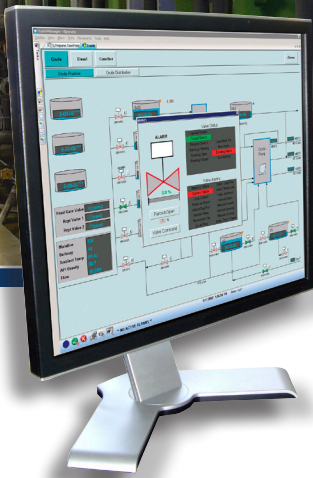

**Varec's inventory management and automation software is ideally suited to industrial applications, such as storing, managing or processing bulk liquids in the water and wastewater industries.**

## Control & Automation

*Varec's FuelsManager software is widely used in the oil and gas industry for monitoring bulk liquid inventories and controlling the flow of liquids throughout storage facilities. It is also ideally suited to other industries that store, manage or process bulk liquids, such as the water and wastewater industries.*

*The Professional Edition provides a tank storage monitoring, inventory management, and product movement solution for operators of bulk liquid storage facilities. It provides all the standard edition features for visualizing bulk liquid assets, alarms and reports; and adds additional functionality, such as networking, integration, SCADA, automation, and the ability to create custom HMI graphic screens.*

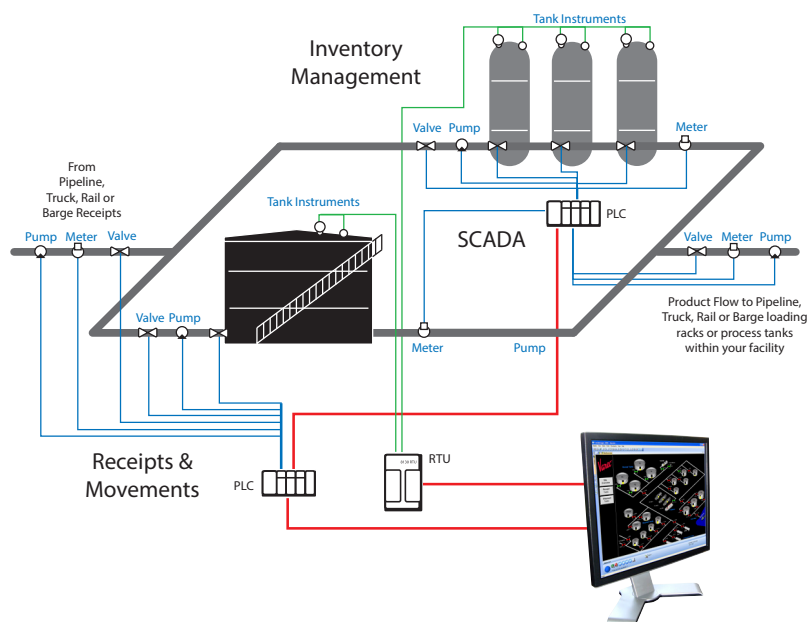



# Liquid Storage Management

For the Food and Beverage Industries

Varec's involvement with independently-operated liquid terminals, regional storage, pipeline or distribution companies, major oil companies, and nationally-owned energy companies has provided us with extensive knowledge and proven experience you can rely on — no matter how small or large your operation.

## Tank Storage Monitoring

- Tank Gauging Integration
- Industry Standard Volume Calculations
- Single and Multiple Tank Displays
- Alarm and Event Management
- Daily Physical Inventory Reports
- Inventory Trend Analysis
- OPC

## Tank Storage Automation

- Multiple Users/Operators (Client/Server)
- Custom HMI Graphics
- Facility Automation
- PLC Support
- Host Systems Integration
- Advanced Scripting and Application Programming Interface

## Leak Detection (Optional Module)

- Interface to Third-party Systems
- Monitor for Leaks Using High Accuracy Tank Gauges
- Static or Continuous Detection

## Online Inventory Reporting (Optional Module)

- 24x7 Online Access to Inventory Reports
- 24x7 Online Access to Tank Graphics

## Throughput Calculations (Optional Module)

- Calculate Tank Throughput in Real Time
- Estimate Emissions
- Export Data in EPA TANKS format

## Product Movement Tracking (Optional Module)

- Industry Standard and Custom Movements or Transfers
- Real-time, Automated Tracking and Alarms
- Daily Accounting, Reports and Tickets

## Integration & Support

- Systems Integration
- Custom Report Development
- Software Application Development
- Software Support Agreements
- 24x7 Technical Support and Help Desk

